

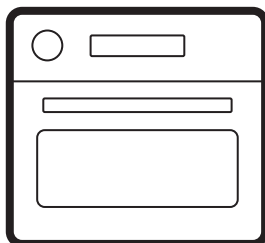

Electrolux



[electrolux.com/register](https://electrolux.com/register)



COMP00CB  
EOQKPB0B0  
EOQKPB0V0  
KVLCE00GH

## INSTALLATION / UPPSETNING

(\*mm)

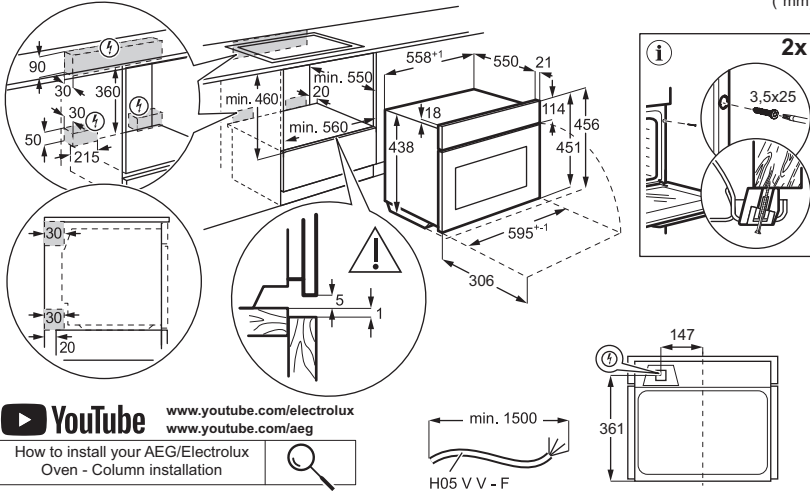

(\*mm)

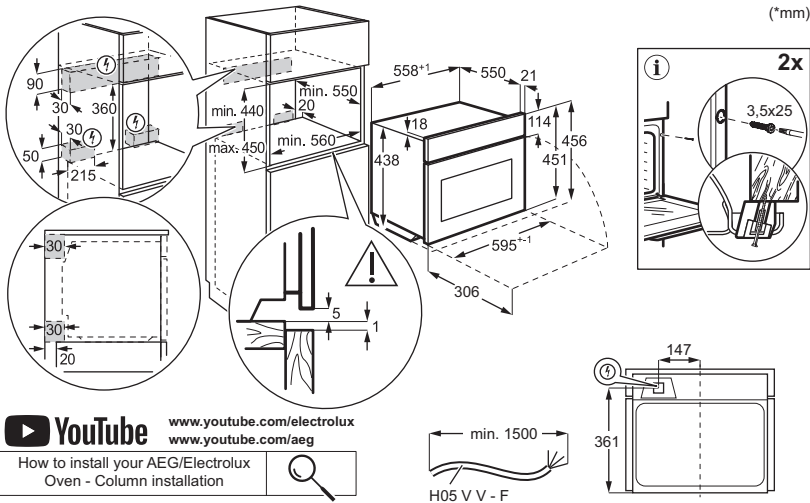

Subject to change without notice.

1. SAFETY INFORMATION.....	3	6. HINTS AND TIPS.....	11
2. SAFETY INSTRUCTIONS.....	5	7. CARE AND CLEANING.....	14
3. PRODUCT DESCRIPTION.....	7	8. TROUBLESHOOTING.....	14
4. BEFORE FIRST USE.....	7	9. ENERGY EFFICIENCY.....	14
5. DAILY USE.....	8	10. ENVIRONMENTAL CONCERNS.....	15

## 1. SAFETY INFORMATION

Before the installation and use of the appliance read the supplied instructions carefully. The manufacturer is not responsible for any injuries or damage that result from incorrect installation or usage. Always keep the instructions in a safe and accessible location for future reference.

### 1.1 Children and vulnerable people safety

- This appliance can be used by children aged from 8 years and above and persons with reduced physical, sensory or mental capabilities or lack of experience and knowledge if they have been given supervision or instruction concerning the use of the appliance in a safe way and understand the hazards involved. Children of less than 8 years of age and persons with very extensive and complex disabilities shall be kept away

- from the appliance unless continuously supervised.
- Children should be supervised to ensure that they do not play with the appliance.
- Keep packaging away from children and dispose of it properly.
- **WARNING:** The appliance and its accessible parts become hot during use. Keep children and pets away during use and cooling.
- Activate the child safety device, if available.
- Children must not clean or maintain the appliance without supervision.

### 1.2 General Safety

- This appliance is for cooking purposes only.
- This appliance is designed for single household domestic use in an indoor environment.
- This appliance may be used in offices, hotel guest rooms, bed & breakfast guest rooms, farm guest

houses, and other similar accommodation where such use does not exceed average domestic usage levels.

- Do not use the appliance before installing it in the built-in structure.
- Disconnect the appliance from the power supply before carrying out any maintenance.
- If the supply cord is damaged, it must be replaced by the manufacturer, its authorised service centre or similarly qualified persons to avoid an electrical hazard.
- **WARNING:** Ensure that the appliance is switched off before replacing the lamp to avoid the possibility of electric shock.
- **WARNING:** The appliance and its accessible parts become hot during use. Care should be taken to avoid touching heating elements or the surface of the appliance cavity.
- Always use oven gloves to remove or insert accessories or ovenware.
- Do not activate the microwave function when the appliance is empty to avoid electric arcing.
- Do not use metallic containers for food and beverages during microwave cooking unless specified by the manufacturer.
- **WARNING:** If the door or door seals are damaged, do not operate the appliance until repaired by a qualified person.
- **WARNING:** Only a qualified person should perform service or repair operations involving the removal of covers protecting against microwave energy exposure.
- **WARNING:** Do not heat liquids or foods in sealed containers to prevent explosions.
- Use only utensils suitable for microwave ovens.
- Observe the appliance when heating food in plastic or paper containers to prevent ignition.
- The appliance is intended for heating food and beverages. Drying of food or clothing and heating of warming pads, slippers, sponges, damp cloth and similar may lead to risk of injury, ignition or fire.
- If smoke is emitted, switch off or unplug the appliance

and keep the door closed in order to stifle any flames.

- Microwave heating of beverages can result in delayed eruptive boiling. Care must be taken when handling the container.
- Stir or shake the contents of feeding bottles and baby food jars and check the temperature before consumption to avoid burns.
- Do not heat eggs in their shells or whole hard-boiled eggs as they may explode, even after microwave heating has ended.
- To remove the shelf supports first pull the front of the shelf support and then the rear end away from the side walls. Install the shelf

supports in the opposite sequence.

- Clean the appliance regularly and remove any food deposits.
- Do not use a steam cleaner to clean the appliance.
- Do not use harsh abrasive cleaners or sharp metal scrapers to clean the glass door since they can scratch the surface, which may result in shattering of the glass.
- Failure to maintain the appliance in a clean condition could lead to deterioration of the surface that could adversely affect the life of the appliance and possibly result in a hazardous situation.

## 2. SAFETY INSTRUCTIONS

### 2.1 Installation

#### **WARNING!**

Only a qualified person must install this appliance.

- Remove all the packaging.
- Do not install or use a damaged appliance.
- Follow the installation instructions available on our website.
- Be careful when moving the appliance, as it is heavy. Use safety gloves and enclosed footwear.
- Do not pull the appliance by the handle.
- Install the appliance in a safe and suitable location that meets installation requirements.
- Keep the minimum distance from other appliances and units.

- Before mounting the appliance, ensure it is level and that the door opens without any restraint.
- The appliance is equipped with an electric cooling system. It must be operated with the electric power supply.

### 2.2 Electrical connection

#### **WARNING!**

Risk of fire and electric shock.

- All electrical connections should be made by a qualified electrician.
- Make sure the parameters on the rating plate are compatible with the electrical ratings of the mains power supply.
- The appliance must be earthed. Always use a correctly installed shockproof socket.

- Do not use multi-plug adapters and extension cables.
- Avoid damaging the mains plug and cable. If replacement is needed, it must be done by our Authorized Service Centre.
- Do not let mains cables touch or come near the appliance door or the niche below, especially when it operates or the door is hot.
- Shock protection of live and insulated parts must be fastened securely and should not be removable without tools.
- Connect the mains plug to the socket only at the end of installation. Ensure access to the mains plug after installation.
- If the mains socket is loose, do not connect the mains plug.
- Do not disconnect the appliance by pulling on the mains cable. Always pull on the mains plug.
- Use only correct isolation devices: line protecting cut-outs, fuses (screw type fuses removed from the holder), earth leakage trips and contactors.
- The electrical installation must have an isolation device that disconnects the appliance from the mains at all poles, with a contact opening width of at least 3 mm.
- This appliance is supplied with a main plug and a main cable.

## 2.3 Use

### **WARNING!**

Risk of injury, burns and electric shock or explosion.

- Do not change the specification of the appliance.
- Ensure ventilation openings are not blocked.
- Do not let the appliance stay unattended during operation.
- Deactivate the appliance after each use.
- Be careful when opening the appliance door during operation, as hot air and flammable mixtures from alcohol ingredients can be released.
- Do not operate the appliance with wet hands or when it comes in contact with water.
- Do not apply pressure on the open door.
- Do not use the appliance as a work surface or as a storage surface.
- Keep sparks and open flames away from the appliance when the door is open.
- Do not place flammable products near the appliance.

- Do not use microwave function to preheat the appliance.

### **WARNING!**

Risk of damage to the appliance.

- To prevent damage or discoloration to the enamel:
  - do not place aluminum foil directly on the cavity bottom.
  - do not put water directly into the hot appliance.
  - do not leave moist dishes and food in the appliance after cooking.
  - be careful when removing or installing accessories.
- Enamel or stainless steel discoloration does not affect performance of the appliance.
- Use a deep pan for moist cakes, as fruit juices can cause permanent stains.
- Use only accessories supplied with this appliance or recommended by the manufacturer.
- Always cook with the appliance door closed.
- If the appliance is installed behind a furniture panel, do not close the panel during use or until the appliance is fully cooled to prevent heat and moisture damage.
- Concerning the lamp(s) inside this product and spare part lamps sold separately: These lamps are intended to withstand extreme physical conditions in household appliances, such as temperature, vibration, humidity, or are intended to signal information about the operational status of the appliance. They are not intended to be used in other applications and are not suitable for household room illumination.
- This product contains a light source of energy efficiency class G.
- Use only lamps with the same specifications.
- To repair the appliance contact the Authorised Service Centre. Use original spare parts only.

## 2.4 Care and cleaning

### **WARNING!**

Risk of injury, fire, or damage to the appliance.

- Before maintenance, deactivate the appliance and unplug it from the mains.

- Ensure the appliance is cold to avoid glass breakage. If the door glass panels are damaged, contact the authorized service centre for replacement.
- Clean and dry the appliance, its cavity, and accessories after each use to prevent steam condensation, corrosion, and surface deterioration.
- Fat and food remaining in the appliance can cause fire and electrical arcing when the microwave function operates.
- Use a microfibre cloth, warm water, and neutral detergents for cleaning the appliance and accessories. Do not use abrasive products, pads, solvents, sharp-edged or metal objects.

- Follow safety instructions on packaging when using an oven spray.

## 2.5 Disposal

### **⚠ WARNING!**

Risk of injury or suffocation.

- Contact your municipal authority for information on how to dispose of the appliance.
- Disconnect the appliance from the mains, then cut off and dispose of the electrical cable.

## 3. PRODUCT DESCRIPTION

### 3.1 General overview

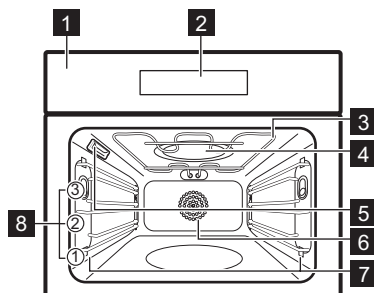

- 1** Control panel
- 2** Display
- 3** Heating element
- 4** Microwave generator
- 5** Lamp
- 6** Fan

- 7** Shelf support, removable

- 8** Shelf positions

### 3.2 Touch fields

	To turn the appliance on and off.
	To navigate the menu.
	To adjust settings.
	Press to set the function: Microwave.
	To set assisted cooking function.
	To set timer functions.
	To enter settings.
	To confirm your selection.

## 4. BEFORE FIRST USE

### 4.1 Setting the time

1. Press **+** or **-** to adjust the hours and minutes.
2. Press **OK** to confirm.

### 4.2 Initial preheating and cleaning

1. Preheat the empty appliance to remove any odours. Ventilate the room.

2. Remove all accessories and shelf supports.
3. Set each function to maximum temperature and let the appliance operate for specified durations: 1 h, 15 min, 15 min. Refer to Daily use.
4. Turn off the appliance and let it cool down.

- Clean with a microfiber cloth, warm water, and mild detergent. Replace accessories and shelf supports.



## 5. DAILY USE

### 5.1 Heating functions





#### Standard heating functions

	<b>True Fan Cooking:</b> Even baking, tenderness, drying
	<b>Conventional Cooking:</b> Traditional baking
	<b>AirFry:</b> Frying food with less oil and without baking paper.
	<b>Frozen Foods:</b> French fries, potato wedges, spring rolls
	<b>Pizza Function:</b> Baking pizza
	<b>Bottom Heat:</b> Baking cakes
	<b>Grill:</b> Toasting, grilling
	<b>Turbo Grilling:</b> Roasting meat, browning

#### Microwave functions

	<b>Defrost:</b> Defrosting various types of food, power range: 100 - 200 W
	<b>Reheat:</b> Heating up pre-prepared meals, power range: 300 - 700 W
	<b>Microwave:</b> Heating up, cooking, power range: 100 - 1000 W







#### Microwave combi functions

	<b>Turbo Grilling + MW:</b> Roasting large pieces, baking gratins, power range: 100 - 400 W.
	<b>True Fan Cooking + MW:</b> Baking, power range: 100 - 400 W.
	<b>Conventional Cooking + MW:</b> Baking, roasting, power range: 100 - 400 W.
	<b>Grill + MW:</b> To grill and brown food on one shelf position. Function with MW boost, power range: 100 - 400 W.







To change the function, press  to switch the appliance off, then press it again to turn it back on.

The lamp may turn off automatically at a temperature below 80°C during some oven functions.



### 5.2 Setting: Heating functions

- Press  to turn on the appliance.
  - Press  or  to navigate functions.
  - Press  or  to set the temperature.
  - Press **OK**.
  - Press  to turn off the heating function.
-  Progress bar - visually indicates when the appliance reaches the set temperature or when the cooking time comes to an end.







### 5.3 Timer

- Press .
- Press  or  to select a timer function.
- Press  or  to set the time. Press **OK**. To cancel a timer function, press and hold for 3 seconds .

#### Timer functions

	Set a countdown. When the timer ends, the signal sounds.
	Set a countdown. When the timer ends, the signal sounds and the cooking stops.
	To postpone the start and / or end of cooking.
<b>Uptimer</b>	To show how long the appliance operates from the moment you start a function. You can reset it from the timer menu.

### 5.4 Setting: Microwave functions

- Remove all accessories, except the wire shelf.
- Insert the food into the appliance.
- Press  to turn on the appliance.
- Press  to enter functions. To navigate press  or .
- To adjust the microwave power press  or . Press **OK**.

- To adjust the duration press  $+$  or  $-$ . Press **OK**.

You can adjust settings while cooking.

**i** If you open the door, the microwave function stops. To start it again, close the door. Press **OK**.

## 5.5 Setting: Microwave combi functions

Microwave combi functions combine standard heating functions with microwave boost to shorten cooking time and improve cooking results.

- Remove all accessories, except the wire shelf.
- Insert the food into the appliance.
- Press  $\text{⓪}$  to turn on the appliance.
- To navigate press  $\wedge$  or  $\vee$  to reach microwave combi functions.
- To adjust the microwave power and temperature press  $+$  or  $-$ . Press **OK**.

You can adjust settings while cooking.

## 5.6 Setting: Assisted Cooking $\text{☞}$

Assisted Cooking submenu consists of a set of additional heating functions and programmes that are designed for dedicated dishes. Programmes start with a suitable setting. You can adjust the time, temperature and if available microwave power during cooking.

- Press  $\text{⓪}$  to turn on the appliance.
- Press  $\text{☞}$ .
- Press  $\wedge$  or  $\vee$  to select assisted cooking functions.
- Press  $+$  or  $-$  to adjust settings if needed.
- Press **OK** to confirm.
- When the function ends, check if the food is ready. Extend the cooking time, if needed. For assisted cooking with food probe the procedure is the same.

### Submenu: Assisted Cooking

#### Legend

$\text{☞}$  Function with microwave power. Use microwave safe accessory.

#### Legend

- $\text{☞}$  Preheat the appliance before you start cooking.
- $\text{☞}$  Shelf level. Refer to Product description.

#### Dishes

$\text{☞}$ <b>Pizza</b>	$\text{☞}$ $\text{☞}$ <b>1; baking tray</b> lined with baking paper
$\text{☞}$ <b>Chicken</b> 1000 - 1400 g	$\text{☞}$ <b>1; wire shelf</b> with plate placed directly in centre of cavity bottom Place the chicken directly on the wire shelf with breast side down. After 30 min, turn the chicken upside down.
$\text{☞}$ <b>Beef</b> 1000 - 1500 g; 4 - 6 cm thick pieces	$\text{☞}$ <b>1; baking tray</b> Fry the meat for a few minutes in a hot pan. Insert to the appliance.
$\text{☞}$ <b>Fillets</b> 150 - 300 g	$\text{☞}$ $\text{☞}$ <b>2; ceramic or glass</b> casserole dish on <b>wire shelf</b>
$\text{☞}$ <b>Lasagne</b> 1000 - 1500 g	$\text{☞}$ $\text{☞}$ <b>1; casserole dish</b> on <b>wire shelf</b>
$\text{☞}$ <b>Popcorn</b>	$\text{☞}$ $\text{☞}$ <b>2; casserole dish</b> on <b>wire shelf</b>
$\text{☞}$ <b>Quiche</b> 4.5 cm thick	$\text{☞}$ $\text{☞}$ $\text{☞}$ <b>1; springform tin</b> on <b>wire shelf</b>
$\text{☞}$ <b>Potatoes</b> 1000 g of fresh potatoes	$\text{☞}$ $\text{☞}$ <b>2; baking tray</b>
$\text{☞}$ <b>Vegetable gratin</b> 1000 - 1500 g	$\text{☞}$ <b>1; baking tray</b> lined with baking paper
$\text{☞}$ <b>Muffins</b> 10 to 20 pieces	$\text{☞}$ $\text{☞}$ <b>2; baking tray</b>
$\text{☞}$ <b>Ciabatta</b> 600 - 800 g of fresh dough	$\text{☞}$ $\text{☞}$ <b>2; baking tray</b> lined with baking paper

## 5.7 Changing: Settings $\text{⚙}$

- Press  $\text{⓪}$  to turn on the appliance.
- Press  $\text{⚙}$  to access settings.

3. Press  $\wedge$  or  $\vee$  to adjust settings. Press OK.
4. Press  $+$  or  $-$  to adjust value.
5. Press OK to confirm or exit adjustment mode.
6. Press  to exit settings.

### Submenu: Settings

Setting	Value
01 -	-
02 Time of day	Change
03 Light	On / Off
04 Fast Heat Up	On / Off
05 Uptimer	On / Off
06 Display brightness	1 - 5
07 Key tones	Beep, Clic, None
08 Buzzer volume	1 - 4
09 -	-
10 Food Sensor <sup>1)</sup>	1 $\mathcal{R}$ - Alarm, 2 $\mathcal{R}$ - Alarm and stop
11 Cleaning Remind-er <sup>1)</sup>	On / Off
12 -	-
13 Demo mode	Activation code: 2468
14 Software version	Check
15 Reset all settings	Yes / No

<sup>1)</sup> selected models only



Settings by default start at **02**. Use the  $\wedge$  and  $\vee$  to navigate.

### 5.8 Lock

This function prevents an accidental change of the appliance function.

When activated while the appliance is in use, it locks the control panel ensuring that the current cooking settings continue uninterrupted.

When activated while the appliance is off, it keeps the control panel locked, preventing the appliance from being turned on unintentionally.

  - press and hold to turn on and off the function.

 - flashes 3 times when the lock is turned on.

## 5.9 Accessories



Accessories available depending on model. Scan the QR code to check how to use accessories supplied with your appliance. You can order optional accessories separately. For more information, please contact your local supplier.

Use only suitable cookware and material. Refer to "Hints and tips" chapter, Microwave suitable cookware and materials.

A small indentation at the top increases safety and provides tilt protection. The rim around the shelf prevents cookware from slipping off the shelf.

Insert the accessory (wire shelf / tray) between the guide bars of the shelf support. Make sure that the shelf touches the back of the oven interior and the feet point down.

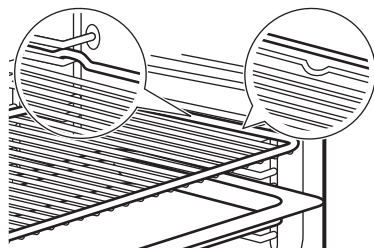

If your tray has a slope, position it towards the back of the oven interior.

If your wire shelf has a step, position it towards the front of the oven interior.

If there is an inscription on the accessory, make sure it is facing you.

If you are using a tray with holes, place the tray / pan underneath to collect dripping liquids.

## 6. HINTS AND TIPS







### 6.1 Cooking recommendations

The temperature and cooking times in the tables are for guidance only. They depend on the recipes, quality and quantity of the ingredients used. If you cannot find the settings for a specific recipe, look for a similar one.

Cooking and baking processes are only suitable on one level.

Count the shelf positions from the bottom of the oven floor.











#### Symbols used in the tables:









	Food type
	Heating function
	Temperature
	Microwave power (W)
	Shelf position
	Cooking time (min)
	Additional information

### 6.2 Information for test institutes

#### Baking on one level

Tests according to EN 60350-1, IEC 60350-1.















				
Small cakes, 20 per tray				
	2	150	18 - 28	1) 2)
	2	150	18 - 28	1) 2)
Fatless sponge cake				
	1	170	25 - 35	3) 2)
	1	170	28 - 38	3) 2)
Shortbread				
	2	140	28 - 38	1) 2)
	2	140	25 - 35	1) 2)
Apple pie				

				
	1	170	65 - 75	3) 4)
	1	170	57 - 67	3) 4)
Toast				
	2	230	7 - 12	3) 2) 5)

- 1) Use the baking tray with the slope towards the back of the oven interior. It must touch the fan cover.
- 2) Preheat the appliance until set temperature is reached. Do not use the function: Fast Heat Up.
- 3) Use wire shelf.
- 4) 2 tins placed diagonally (Ø 20 cm). The right one to be positioned more in the front than the left one.
- 5) According to: IEC 60350-1:2016 and IEC 60350-1:2023.

#### Microwave and microwave combi functions

Tests according to EN 60705, IEC 60705.

						
Sponge cake						
	1	500	-	8 - 10	1) 2)	
Meatloaf						
	1	300	-	30 - 35	1) 2) 3)	
Egg custard						
	1	400	-	18 - 23	1) 4)	
Defrosting minced meat (500 g)						
	1	200	-	7 - 8	1) 5)	
Cake						
		1	200	170	22 - 27	1) 4)
Potato gratin						
		1	200	180	35 - 40	1) 6)
Chicken (1100 g)						

		POWER	°C		
	1	200	30	1) 7)	
	-	200	18 - 23		

- 1) Use wire shelf. It must touch the fan cover.
- 2) Turn container around by 1/2, halfway through the cooking time.
- 3) Use MW suitable clingfilm during cooking. Prick the clingfilm several times before cooking.
- 4) Do not turn the food during the cooking process.
- 5) Turn the meat upside down over the longest side, one time after 1/3 and a second time after 2/3 of the elapsed cooking time.
- 6) Turn container clockwise by 1/4, halfway through the cooking time.
- 7) Place a plate at the bottom of the oven. Place chicken directly on wire shelf with breast side down. After 30 min, turn the chicken upside down and change the heating function to: Turbo Grilling.

### Additional recipes

		POWER	°C		
<b>Meringues</b>					
	2	-	100	90 - 180	1) 2) 3)
	2	-	100	90 - 180	1) 2) 3)
<b>Scones</b>					
	3	-	200	11 - 13	1) 3)
	3	-	190	10 - 12	1) 3)
<b>Chicken</b>					
	1	-	200	65 - 75	1) 4)
<b>Popcorn</b>					
	-	700	-	3 - 4	5) 6)
<b>Plated meals, chilled (1 portion)</b>					
	1	500	-	7 - 9	7) 8) 9)
<b>Liquids in baby bottles</b>					
	-	1000	-	0.5	10)
<b>Lasagne, frozen (400 g)</b>					
	1	100	210	23 - 28	7) 11)
<b>Lasagne, frozen (600 g)</b>					
	1	200	190	48 - 53	7) 11)

		POWER	°C		
<b>Pizza, frozen</b>					
	1	200	210	12 - 16	7) 11)

- 1) Use baking tray with the slope towards the back of the oven interior.
- 2) Use baking paper.
- 3) Preheat the appliance until set temperature is reached. Do not use the function: Fast Heat Up.
- 4) Place chicken with breast side down. Turn it upside down halfway through the cooking time.
- 5) Use flat ceramic plate on the cavity bottom.
- 6) The bag should be taken out of the appliance when the kernels stop popping.
- 7) Use wire shelf. It must touch the fan cover.
- 8) Cover the food with a microwavable plastic lid.
- 9) Turn container around by 1/2, halfway through the cooking time.
- 10) Position the bottle in the centre of the cavity bottom without using any accessories.
- 11) Do not turn the food during the cooking process.

### 6.3 Microwave recommendations

Place the food in the centre of the wire shelf. Use first shelf position.

Turn or stir the food halfway through the cooking time to improve the results.

Stir liquid dishes from time to time.

Stir the food before serving.

Put the spoon into the cup or glass when heating up liquids, to improve heat distribution and avoid overboiling. The spoon must not touch any part of the oven interior, this may cause sparking.

Place the food into the appliance without packaging. The packaged ready meals can be put into the appliance only when the packaging is microwave safe. Refer to Hints and tips, Microwave suitable cookware and materials section.

Do not cover the food when using Microwave combi functions. Refer to Daily use.

Do not use Microwave functions or Microwave combination functions when there is no food inside the appliance.

### Microwave cooking

Cover the food for cooking or reheating with microwave functions. If you want to keep a crust, cook food without a cover.

Do not overcook the dishes by setting the power and time too high. The food can dry out, burn or cause fire.

Do not use the appliance to cook eggs or snails in their shells, because they can burst. Pierce the yolk of fried egg before reheating it.

Pierce food with skin or peel several times before cooking.

Cut vegetables into similar-sized pieces.

After you turn off the appliance, take the food out and let it stand for a few minutes to allow the heat distribute evenly.

### Microwave defrosting

Place the frozen, unwrapped food on a small upturned plate with a container below it, or on a defrosting rack or plastic sieve so that the defrosting liquid can leak out.

Remove defrosted pieces subsequently.

To cook fruit and vegetables without defrosting them first, you can use a higher microwave power.







Turning improves the results. For sensitive foods such as meat, turn upside down twice during defrosting.

### 6.4 Microwave suitable cookware and materials

For the microwave use only suitable cookware and materials. Use below table as a reference.

Check the cookware / material / food container specification before use.

For other specific microwave cookware not listed in this table, follow manufacturer instructions.

Cookware / Material						
Ovenproof glass and porcelain with no metal components, e.g. heat-proof glass	✓	✓	✓	✓	✓	✓
Non-ovenproof glass and porcelain without any silver, gold, platinum or other metal decorations	✓	✗	✗	✗	✗	✗
Glass and glass ceramic made of ovenproof / frost-proof material	✓	✓	✓	✓	✓	✓
Ovenproof ceramic and earthenware without any quartz or metal components and glazes which contain metal	✓	✓	✓	✓	✓	✓
Ceramic, porcelain and earthenware with unglazed bottom or with small holes, e.g. on handles	✗	✗	✗	✗	✗	✗
Heat-resistant plastic up to 200 °C	✓	✓	✓	✗	✗	✗
Cardboard, paper only	✓	✗	✗	✗	✗	✗
Clingfilm	✓	✗	✗	✗	✗	✗
Microwave clingfilm	✓	✓	✓	✗	✗	✗
Roasting dishes made of metal, e.g. enamel, cast iron	✗	✗	✗	✗	✗	✗
Baking tins, black lacquer or silicon-coated	✗	✗	✗	✗	✗	✗
Baking tray	✗	✗	✗	✗	✗	✗
Wire shelf	✓	✓	✓	✓	✓	✓

### 6.5 Power settings

Below data is for guidance only.

#### 800 - 1000 W

- Heating up liquids

#### 600 - 700 W

- Simmering rice
- Cooking vegetables
- Popcorn

#### 400 - 500 W

- Heating one-plate meals
- Simmering stews

- Defrosting and heating ready frozen meals

### 300 W

- Cooking / Heating delicate food
- Heating baby food
- Continuing cooking

### 100 - 200 W

- Defrosting bread, fruit, cakes, pastries, cheese, butter, meat and fish
- Melting chocolate and butter

## 7. CARE AND CLEANING

### 7.1 Notes on cleaning

- Use a cleaning solution for metal surfaces.
- Use the liquid descaler recommended by the manufacturer to remove limestone residue.
- Do not store food in the appliance for longer than 20 minutes.
- Do not clean the accessories in a dishwasher.

### 7.2 Removing the shelf supports

1. Make sure the appliance is cold.
2. Carefully pull the shelf supports up and out of the front catch.
3. Pull the supports out of the rear catch.

4. Put the shelf supports back to the initial position. Repeat the steps in the reverse order.

If the telescopic runners are supplied, its retaining pins must point to the front.

### 7.3 Replacing the lamp

#### **WARNING!**

Risk of burns, the glass cover may be hot. Use protective glove when touching the lamp.

Only service is allowed to replace the lamp. Contact your Authorised Service Centre.

## 8. TROUBLESHOOTING

If you cannot find a solution to the problem yourself, contact your dealer or an Authorised Service Centre. Service details are on the rating plate, located on the front frame. It is visible when you open the door. Do not remove the rating plate.

If the display shows an error code that is not in this table, turn the house fuse off and on to restart the appliance. If the error code recurs contact an Authorised Service Centre.

**You cannot activate or operate the appliance.** - The appliance is not connected to an electrical supply or it is connected incorrectly.

#### **The appliance does not heat up.**

- Lock is activated.
- Automatic switch-off is activated.

**The lamp does not work.** - The lamp is burnt out. Lamp needs to be replaced, contact an Authorised Service Centre.

**The display shows "00:00".** - There was a power cut. Set the time of day.

## 9. ENERGY EFFICIENCY

### 9.1 Information requirements according to (EU) No 2023/826

Power consumption in standby	0.8 W
Maximum time needed for the equipment to automatically reach the applicable low power mode	20 min

Appliance tested according to: EN 50564.

### 9.2 Energy saving tips

- Keep the door closed during cooking and avoid opening it often.
- Keep the door gasket clean and make sure it is well fixed in its position.
- Use metal or dark, non-reflective cookware (only when you use a non-microwave function).
- Skip preheating unless needed.

- Minimize breaks between baking multiple dishes.
- When possible, use the cooking functions with fan to save energy (selected models only).
- Use residual heat to keep food warm. Reduce the appliance temperature to minimum 3 - 10 min before the end of cooking.
- Turn off the lamp during cooking unless needed. Refer to Settings.
- Moist Fan Baking (selected models only) - this function was used to comply with the energy efficiency class and ecodesign requirements (according to EU 65/2014 and EU 66/2014). Tests according to: IEC/EN 60350-1. The oven door should be closed during cooking so that the function is not interrupted and the oven operates with the highest energy efficiency possible. When you use this function the lamp automatically turns off. In some models it takes 30 sec.
- Automatic switch-off - for safety reasons, if the heating function is active and no settings are changed, the appliance will turn off automatically after a certain period of time. If you intend to run a heating function for a duration exceeding the automatic switch-off time, set the cooking time.
  - 12.5 h: 30-115 °C
  - 8.5 h: 120-195 °C
  - 5.5 h: 200-245 °C
  - 3 h: 250-maximum °C

## 10. ENVIRONMENTAL CONCERNS

Recycle materials with the symbol . Put the packaging in relevant containers to recycle it. Help protect the environment and human health by recycling waste of electrical and electronic appliances. Do not dispose of ap-

pliances marked with the symbol  with the household waste. Return the product to your local recycling facility or contact your municipal office.

1. ÖRYGGISUPPLÝSINGAR.....	16	6. ÁBENDINGAR OG GÓÐ RÁÐ.....	24
2. ÖRYGGISLEIÐBEININGAR.....	18	7. UMHIRÐA OG HREINSUN.....	27
3. VÖRULÝSING.....	20	8. BILANALET.....	28
4. FYRIR FYRSTU NOTKUN.....	21	9. ORKUNÝTNI.....	28
5. DAGLEG NOTKUN.....	21	10. UMHVERFISSJÓNARMÍÐ.....	29

## 1. ⚠ ÖRYGGISUPPLÝSINGAR

Fyrir uppsetningu og notkun heimilistækisins skal lesa meðfylgjandi leiðbeiningar vandlega. Framleiðandinn ber ekki ábyrgð á neinum meiðslum eða skemmdum sem leiða af rangri uppsetningu eða notkun. Geymdu alltaf leiðbeiningarnar á öruggum stað þar sem auðvelt er að nálgast þær til síðari notkunar.

### 1.1 Öryggi barna og viðkvæmra einstaklinga

- Börn, 8 ára og eldri og fólk með minnkaða líkamlega-, skyn- eða andlega getu, eða sem skortir reynslu og þekkingu, mega nota þetta tæki, ef þau eru undir eftirliti eða hafa verið veittar leiðbeiningar varðandi örugga notkun tækisins og ef þau skilja hættuna sem því fylgir. Halda skal börnum yngri en 8 ára gömlum og fólki með mjög miklar og flóknar

fatlanir frá heimilistækinu, nema þau séu undir stöðugu eftirliti.

- Hafa ætti eftirlit með börnum til að tryggja að þau leiki sér ekki með heimilistækið.
- Haltu öllum umbúðum frá börnum og fargaðu þeim á viðeigandi hátt.
- VIÐVÖRUN: Heimilistækið og aðgengilegir hlutar þess hitna meðan á notkun stendur. Haltu börnum og gæludýrum frá meðan á notkun stendur og meðan tækið kólnar.
- Kveiktu á barnalæsingunni ef hún er í boði.
- Börn mega ekki þrifa eða annast viðhald á tækinu án eftirlits.

### 1.2 Almennt öryggi

- Þetta heimilistæki er eingöngu ætlað til matreiðslu.

- Þetta heimilistæki er hannað til notkunar innanhúss á heimilum.
- Þetta heimilistæki má nota á skrifstofum, í herbergjum hótela, herbergjum gestahúsa, bændagistingum og öðrum sambærilegum gistirýmum þar sem notkun er ekki meiri en almenn heimilisnotkun.
- Ekki má nota heimilistækið fyrr en innbyggða virkið hefur verið uppsett.
- Aftengdu heimilistækið frá rafmagns- og vatnsinntaki áður en hvers kyns viðhaldsvinna fer fram.
- Ef rafmagnssnúran skemmist skal framleiðandi, viðurkennd þjónustumiðstöð hans eða hæfir aðilar skipta henni út til að koma í veg fyrir rafmagnshættu.
- VIÐVÖRUN: Tryggðu að slökkt sé á heimilistækinu áður en þú skiptir um ljósið til að forðast möguleika á raflosti.
- VIÐVÖRUN: Heimilistækið og aðgengilegir hlutar þess hitna meðan á notkun stendur. Gæta ætti varúðar þegar hitunarelementin eru snert eða yfirborð holrýmis heimilistækisins.
- Notaðu alltaf hanska við að taka úr og setja í aukahluti eða eldföst matarílát.
- Ekki kveikja á örbylgjuágerðinni þegar heimilistæk-ið er tómt til að koma í veg fyrir neistahlaup.
- Ekki nota ílát úr málmi fyrir mat eða drykki við örbylgjueldun nema framleiðandinn tilgreini það sérstaklega.
- VIÐVÖRUN: Ef hurðin eða þéttingarnar eru skemmdar má ekki nota tækið fyrr en fagaðili hefur gert við það.
- VIÐVÖRUN: Einungis hæfur sérfræðingur má framkvæma þjónustu eða viðgerðir sem fela í sér að fjarlægja hlífar sem vernda gegn útsetningu fyrir örbylgjuorku.
- VIÐVÖRUN: Ekki hita vökva eða mat í lokuðum ílátum til að koma í veg fyrir sprengingar.
- Notaðu aðeins áhöld sem henta til notkunar í örbylgjuofnum.
- Þegar matur er hitaður í plast- eða pappírslátum skal hafa auga með heimilistækinu vegna hugsanlegrar hættu á íkveikju.
- Heimilisækið er ætlað til þess að hita matvæli og drykki. Þurrkun á matvæl-

um eða fatnaði og upphitun á hlífðarpúðum, inniskóm, svömpum, rökum klútum og öðru slíku getur leitt til hættu á meiðslum, íkveikju eða eldsvoða.

- Ef tækið gefur frá sér reyk, skal slökkva á tækinu eða taka það úr sambandi og hafa hurðina lokaða til að kæfa loga.
- Hitun drykkja með örbylgjum getur leitt til seinkaðrar gossuðu. Gæta verður varúðar við meðhöndlun íláta.
- Hrærðu eða hristu innihald pela og barnamatskrukka og kannaðu hitastigið áður en barnið fær matinn, til að koma í veg fyrir brunasár.
- Ekki má hita egg í skurn eða heil harðsoðin egg í heimilistækinu þar sem þau geta sprungið, jafnvel eftir að örbylgjuhitun lýkur.
- Til þess að taka hillustuðninginn úr skal fyrst toga í

framhluta hillustuðningsins og síðan afturhluta hans frá hliðarveggjunum. Komdu hilluberunum fyrir í öfugri röð.

- Hreinsaðu tækið reglulega og fjarlægðu matarleifar.
- Notaðu ekki gufuhreinsibúnað til að hreinsa heimilis-tækið.
- Notaðu ekki sterk tærandi hreinsiefni eða beittar málmsköfur til að hreinsa glerhurðina þar sem slíkt getur rispað yfirborðið, sem getur aftur leitt til þess að glerið brotnar.
- Sé heimilistækinu ekki haldið hreinu getur það leitt til slits á yfirborðsfletinum sem getur haft neikvæð áhrif á líftíma heimilistækisins og hugsanlega haft hættu í för með sér.

## 2. ÖRYGGISLEIÐBEININGAR

### 2.1 Installation

#### AÐVÖRUN!

Einungis til þess hæfur aðili má setja upp þetta heimilistæki.

- Fjarlægðu allar umbúðir.
- Ekki setja upp eða nota skemmt heimilistæki.
- Fylgdu uppsetningarleiðbeiningunum sem eru á vefsíðu okkar.

- Alltaf skal sýna aðgát þegar heimilistækið er fært til, vegna þess að það er þungt. Notaðu öryggishanska og lokaðan skóbúnað.
- Dragðu heimilistækið ekki á handfanginu.
- Settu heimilistækið upp á öruggum og hentugum stað sem uppfyllir allar uppsetningarkröfur.
- Haltu lágmarksfjarlægð frá öðrum heimilistækjum og einingum.
- Áður en tækið er sett upp skaltu ganga úr skugga um að það standi slétt og að hurðin opnast án hindrana.

- Heimilistækið er útbúið rafstýrðu kælikerfi. Það þarf rafstraum til að geta gengið.

## 2.2 Rafmagnstenging

### ⚠ AÐVÖRUN!

Hætta á eldi og raflosti.

- Allar rafmagnstengingar skulu framkvæmdar af viðurkenndum rafvirkja.
- Gakktu úr skugga um að upplýsingar á merkiplötunni séu í samræmi við rafmagnsgildi rafmagnsnetins.
- Heimilistækið verður að vera jarðtengt. Notaðu alltaf rétt uppsettar einangraðar innstungur.
- Notaðu ekki fjöltengi eða framlengingarsnúur.
- Gættu þess að rafmagnstengill og snúra skemmist ekki. Ef skipta þarf um varahlut skal það gert af viðurkenndri þjónustumiðstöð okkar.
- Láttu rafmagnssnúur ekki snerta hurð tækisins eða svæðið undir henni, sérstaklega þegar tækið er í notkun eða hurðin er heit.
- Raflostvörn á straumvirkum og einangruðum hlutum skal festa tryggilega og hún má ekki vera fjarlægjanleg án verkfæra.
- Aðeins skal tengja rafmagnsklóna við rafmagnsinnstunguna í lok uppsetningarferlisins. Gakktu úr skugga um að auðvelt sé að komast að rafmagnstenglinum eftir uppsetningu.
- Ef aðalrafmagnstengið er laust skaltu ekki stinga í samband.
- Ekki aftengja tækið með því að toga í rafmagnssnúruna. Taktu alltaf í innstunguna sjálfa.
- Notaðu aðeins réttan einangrunarbúnað: Línuvarnarstraumloka, öryggi (öryggi með skrufgangi fjarlægð úr höldunni), lekaliða og spólurofa.
- Rafmagnsuppsetningin verður að vera með einangrunarbúnað sem gerir þér kleift að rjúfa straum til heimilistækisins frá innstungum við alla póla með að minnsta kosti 3 mm snertibil.
- Þessu tæki fylgja rafmagnskló og -snúra.

## 2.3 Notkun

### ⚠ AÐVÖRUN!

Hætta á meiðslum, bruna og raflosti eða sprengingu.

- Breytið ekki eiginleikum heimilistækisins.

- Gakktu úr skugga um að loftræstigötin séu ekki stífluð.
- Látið heimilistækið ekki vera án eftirlits á meðan það er í gangi.
- Slökkvið á heimilistækinu eftir hverja notkun.
- Gættu varúðar þegar hurð tækisins er opnuð meðan á notkun stendur, þar sem heitt loft og eldfim efni úr áfengisinnihaldsefnum geta sloppið út.
- Notaðu ekki heimilistækið með blautar hendur eða þegar það kemst í snertingu við vatn.
- Beitið ekki þrýstingi á opna hurð.
- Notið ekki heimilistækið sem vinnusvæði eða geymslusvæði.
- Gættu þess að neistar og opnir eldar komist ekki nærri tækinu þegar hurðin er opin.
- Ekki geyma eldfimar vörur nálægt tækinu.
- Ekki nota örbylgjuaðgerðina til að forhita heimilistækið.

### ⚠ AÐVÖRUN!

Hætta á eldi og skemmdum á heimilistækinu.

- Til að koma í veg fyrir skemmdir eða aflitun á gljáhúðinni:
  - ekki setja álpappír beint á botn ofnsins.
  - setjið ekki vatn beint inn í heitt heimilistækið.
  - Ekki skilja eftir rök ílát eða mat í heimilistækinu eftir eldun.
  - farðu varlega þegar þú fjarlægir eða setur aukahluti í heimilistækið.
- Aflitun á glerungnum eða ryðfríu stáli hefur engin áhrif á getu eða frammistöðu heimilistækisins.
- Notið djúpt form fyrir blautar kökur, þar sem ávaxtasafi getur valdið varanlegum blettum.
- Notaðu aðeins aukahluti sem fylgja með þessu heimilistæki eða sem framleiðandi þess mælir með.
- Alltaf skal elda með hurð heimilistækisins lokaða.
- Ef tækið er sett upp bak við skápahurð má ekki loka hurðinni meðan á notkun stendur eða fyrr en tækið hefur kólnað alveg, til að koma í veg fyrir skemmdir af völdum hita og raka.
- Varðandi ljós inni í þessari vöru og varaljos sem eru seld sér: Þessum ljósum er ætlað að þola ógafullar aðstæður í heimilistækjum á borð við hitastig, titring, raka eða er ætlað að senda upplýsingar

um notkunarástand tækisins. Þau eru ekki ætluð til að nota í öðrum tækjum og henta ekki sem lýsing í herbergjum heimila.

- Þessi vara inniheldur ljósgjafa í orkunýtniflokki G.
- Notaðu aðeins ljós með sömu tæknilýsingu.
- Hafðu samband við viðurkennda þjónustumiðstöð til að gera við heimilistækið. Notaðu eingöngu upprunalega varahluti.

## 2.4 Umhirða og hreinsun

### ⚠ AÐVÖRUN!

Hætta á meiðslum, eldsvoða eða skemmtum á heimilistækinu.

- Áður en viðhald fer fram skal slökkva á heimilistækinu og taka úr sambandi við rafmagn.
- Gakktu úr skugga um að tækið sé kalt til að forðast að gler brotni. Ef glerplötur hurðarinnar skemmast skaltu hafa samband við viðurkennda þjónustumiðstöð til að láta skipta um þær.

- Hreinsaðu og þurrkaðu heimilistækið, holrými þess og fylgihluti eftir notkun til að forðast tæringu og raka- eða yfirborðsskemmdir.
- Feiti og matarleifar sem verða eftir í heimilistækinu geta valdið eldsvoða og rafneistahlaupi þegar örbylgjuaðgerðin er í gangi.
- Hreinsaðu heimilistækið og fylgihluti eingöngu með trefjaklút, volgu vatni og mildu hreinsiefni. Notaðu ekki neinar vörur með svarfefnum, stálull, leysiefni eða málmhluti.
- Fylgdu öryggisleiðbeiningum á umbúðum þegar notaður er ofnspray.

## 2.5 Förgun

### ⚠ AÐVÖRUN!

Hætta á meiðslum eða köfnun.

- Hafðu samband við staðbundin yfirvöld fyrir upplýsingar um hvernig skuli farga heimilistækinu.
- Taktu heimilistækið úr sambandi, klipptu síðan rafmagnssnúruna og fargaðu henni.

## 3. VÖRULÝSING

### 3.1 Almennt yfirlit

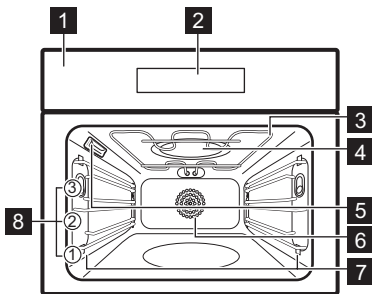

- 1 Stjórnborð
- 2 Skjár
- 3 Hitunareining
- 4 Örbylgjugjafi
- 5 Ljós
- 6 Vífta

7 Hillubera má fjarlægja

8 Hillustöður

### 3.2 Snertifletir

⓪	Til að kveikja og slökkva á heimilistækinu.
^ v	Til að fletta í valmyndinni.
+ -	Til að breyta stillingum.
☰	Ýttu á til að stilla aðgerðina: Örbylgjuofn.
☞	Til að velja eldunaraðstoð.
⌚	Til að stilla tímastilliaðgerðir.
⚙	Til að opna stillingar.
OK	Ýttu á til að staðfesta val þitt.



## 4. FYRIR FYRSTU NOTKUN

### 4.1 tíminn stilltur

1. Ýttu á  $\oplus$  eða  $\ominus$  til að stilla klukkustundir og mínútur..
2. Ýttu á OK til að staðfesta.

### 4.2 Forhitun og hreinsun











1. Forhitaðu heimilistæknið, án innihalds, til að fjarlægja lykt. Loftræstu herbergið.
2. Fjarlægðu alla fylgihluti og lausa hillubera.

3. Stillið hverja aðgerð á hámarkshita og látið tæknið keyra í tilgreindan tíma:  1 klst,  15 mín,  15 mín. Sjá Dagleg notkun.
4. Slökktu á ofninum og láttu hann kólna.
5. Notaðu trefjaklút með volgu vatni og mildu hreinsiefni. Fjarlægðu fylgihluti og lausa hillubera.





## 5. DAGLEG NOTKUN

### 5.1 Upphitunaraðgerðir



#### Staðlaðar hitunaraðgerðir

-  **Eldun með hefðbundnum blæstri:** Jöfn bakstur, meyrnun, þurrkun
-  **Hefðbundin matreiðsla:** Hefðbundinn bakstur
-   **AirFry:** Steiking með minni olíu og án bökunarpappírs.
-   **Frosin matvæli:** Franskar kartöflur, kartöflubátar, vorrúllur
-  **Pítsuaðgerð:** Pítsubakstur
-  **Undirhiti:** Kókubakstur
-  **Grill:** Ristun, grillun
-  **Blástursgrillun:** Steiking á kjöti, brúnun

#### Örbylgjuaðgerðir

-   **Affrysta:** Afbýðing mismunandi tegunda matvæla, orkusvið: 100 - 200 W
-   **Upphita:** Upphitun á tilbúnum máltíðum, orkusvið: 300 - 700 W
-  **Örbylgja:** Upphitun, eldun, orkusvið: 100 - 1000 W

#### Blönduð örbylgjuofnsaðgerð

-   **Túrbógrillun + örbylgja:** Steiking á stórum bitum, bakstur á gratínréttum, orkusvið: 100 - 400 W.

  **Eldað með hefðbundnum blæstri + örbylgja:** Bakstur, orkusvið: 100 - 400 W.



  **Hefðbundin matreiðsla + örbylgja:** Bakstur, steiking, orkusvið: 100 - 400 W.

  **Grill + örbylgja:** Til að grilla og brúna mat á einni braut. Aðgerð með örbylgjuviðbót, orkusvið: 100 - 400 W.

Til að breyta aðgerð skaltu ýta á  til að slökka á heimilistækinu og ýttu síðan aftur á það til að kveikja á því á ný.

Ljósíð kann að slökka á sér sjálfkrafa við hitastig undir 80°C við sumar ofnaðgerðir.

### 5.2 Stilling: Upphitunaraðgerðir

1. Ýttu á  til að kveikja á heimilistækinu.
2. Ýttu á  $\wedge$  eða  $\vee$  til að fletta í gegnum stillingar.
3. Ýttu á  $\oplus$  eða  $\ominus$  til að stilla hitastigið.
4. Ýttu á: OK.
5. Ýttu á  til að slökka á hitunaraðgerðinni.



— Framvindustika - sýnir sjónrænt hvenær heimilistæknið nær settu hitastigi eða hvenær eldunartímanum lýkur.

### 5.3 Tímastillir

1. Ýttu á .

2. Ýttu á  $\wedge$  eða  $\vee$  til að velja tímastilliaðgerð.
3. Ýttu á  $+$  eða  $-$  til að stilla tímann. Ýttu á OK.

Til að hætta við tímastillingu, skaltu halda inni  $\odot$  í 3 sekúndur.

Tímastillingar	
	Stilltu niðurtalinguna. Hljóðmerki heyrst þegar tíminn er liðinn.
	Stilltu niðurtalinguna. Hljóðmerki heyrst þegar tíminn er liðinn og eldun lýkur.
	Til að fresta ræsingu og / eða lokum eldunar.
<b>Uppteljari</b>	Sýnir hversu lengi heimilistækið er í notkun frá því að stillingin er ræst. Endurstilling er möguleg á tímastillingar valmyndinni.

## 5.4 Stilling: Örbylgjuaðgerðir

1. Fjarlægðu allan aukabúnað nema vírhilluna.
2. Settu matinn inn í heimilistækið.
3. Ýttu á  $\odot$  til að kveikja á heimilistækinu.
4. Ýttu á  $\equiv$  til að opna á aðgerðir Til að fletta skaltu ýta á  $\wedge$  eða  $\vee$ .
5. Ýttu á  $+$  eða  $-$ . Ýttu á OK.
6. Til að breyta tímalengdinni, ýttu á  $+$  eða  $-$ . Ýttu á OK.

Þú getur breytt stillingunum á meðan eldun stendur.

 Ef þú opnar hurðina stöðvast örbylgjuaðgerðin. Lokaðu hurðinni á örbylgjuofninum til að halda áfram. Ýttu á OK.

## 5.5 Stilling: Blönduð örbylgjuofnsaðgerð

Samsettar örbylgjuaðgerðir sameina staðlaðar hitunaraðgerðir við aukna örbylgjuorku til að stytta eldunartíma og bæta eldunarárangur.

1. Fjarlægðu allan aukabúnað nema vírhilluna.
2. Settu matinn inn í heimilistækið.
3. Ýttu á  $\odot$  til að kveikja á heimilistækinu.

4. Til að fletta skaltu ýta á  $\wedge$  eða  $\vee$  til að fara í örbylgju-samsetningarstillingar.
5. Til að stilla örbylgjuafli og hitastig skaltu ýta á  $+$  eða  $-$ . Ýttu á: OK.



Þú getur breytt stillingum á meðan eldun stendur.





## 5.6 Stilling: Eldunaraðstoð $\Psi$

























Eldunaraðstoð undirvalmyndin samanstendur af viðbótarhitunaraðgerðum og forritum sem eru hönnuð fyrir tiltekna rétti. Kerfin byrja með viðeigandi stillingu. Þú getur stillt tíma, hitastig og, ef það er tiltækt, örbylgjuafli meðan á meðan stendur.

1. Ýttu á  $\odot$  til að kveikja á heimilistækinu.
2. Ýttu á  $\Psi$ .
3. Ýttu á  $\wedge$  eða  $\vee$  til að velja stillingar fyrir eldunaraðstoð.
4. Ýttu á  $+$  eða  $-$  til að aðlaga stillingarnar ef þörf er á.
5. Ýttu á OK til staðfestingar.
6. Þegar aðgerðinni lýkur skaltu kanna hvort maturinn sé tilbúinn. Framlengdu eldunartímann ef þörf er á. Við eldunaraðstoð með kjóthitamæli er ferlið hið sama.







## Undirvalmynd: Eldunaraðstoð

Merking	
	Stilling með örbylgjuafli. Notaðu ílát sem má fara í örbylgjuofn.
	Forhitaðu heimilistækið áður en eldun hefst.
	hilluhæð. Sjá Vörulýsing.
Réttir	

	<b>Pítsa</b>	  <b>1; bökunarplata</b> klædd með bökunarpappír
	<b>Kjúklingur</b> 1000-1400 g	 <b>1; vírgrind</b> með diskinn lagðan neðst í miðju rýmisins Settu kjúklinginn beint á vírgrindina og snúðu bringunni við. Eftir 30 mín skaltu snúa kjúklingnum á hvolf.



	Réttir
	<b>Nautakjöt</b> 1000 - 1500g; 4 - 6cm þykkir bitar  <b>1; bökunarplata</b> Steiktu kjötið á heitri pönnu í nokkrar mínútur. Settu inn í heimilistækið.
	<b>Flök</b> 150 - 300 g   <b>2; pottréttur í keramik eða glerláti á vírgrind</b>
	<b>Lasagna</b> 1000-1500 g   <b>1; pottréttur á vírhillu</b>
	<b>Poppkorn</b>   <b>2; ófnpottur á vírhillu</b>
	<b>Baka</b> 4,5 cm þykk   <b>1; smelluform á vírhillu</b>
	<b>Kartöflur</b> 1000 g af ferskum kartöflum   <b>2; bökunarplata</b>
	<b>Gratiner-að grænmeti</b> 1000-1500 g  <b>1; bökunarplata</b> klædd með bökunarpappír
	<b>Múffur</b> 10 til 20 stykki   <b>2; bökunarplata</b>
	<b>Ciabatta</b> 600-800 g af fersku deigi   <b>2; bökunarplata</b> klædd með bökunarpappír

## 5.7 Breyting á: Stillingar



1. Ýttu á  til að kveikja á heimilistækinu.
2. Ýttu á  til að opna stillingar.
3. Ýttu á  eða  til að stilla stillingar. Ýttu á **OK**.
4. Ýttu á  eða  til að stilla gildi.
5. Ýttu á **OK** til að staðfesta eða hætta í stillingarham.
6. Ýttu á  til að hætta í stillingum.

### Undirvalmynd: Stillingar

Stilling	Gildi
01 -	-
02 Tími dags	Breyta

Stilling	Gildi
03 Létt	Kveikja / Slökkva
04 Hröð upphitun	Kveikja / Slökkva
05 Upptalning	Kveikja / Slökkva
06 Skjábirta	1 - 5
07 Lykiltónar	Beep, Clic, None
08 Hljóðstyrkur hljóð-gjafa	1 - 4
09 -	-
10 Kjöthitamælir <sup>1)</sup>	1  - Viðvörðun, 2  - Viðvörðun og stöðvun
11 Áminning um hreinsun <sup>1)</sup>	Kveikja / Slökkva
12 -	-
13 Kynningarhamur	Virkunarkóði: 2468
14 Útgáfa hugbúnaðar	Athuga
15 Endursetja allar stillingar	Já / Nei

<sup>1)</sup> aðeins valdar gerðir



Sjálfgefnar stillingar byrja á **02**. Notaðu  og  til að fletta á milli.

## 5.8 Lás

Þessi aðgerð kemur í veg fyrir að aðgerð heimilistækisins breytist óvart.

Þegar aðgerðin er virkjuð á meðan heimilistækið er í notkun læsir hún stjórnborðinu og tryggir að núverandi eldunarstillingar haldi áfram án truflana.

Þegar það er virkjað á meðan heimilistækið er í notkun heldur það stjórnborðinu læstu og kemur í veg fyrir að það sé óvart kveikt á heimilistækinu.

  - ýttu á og haltu inni í þrjár sekúndur til að kveikja og slökkva á aðgerðinni.

 - blikkar þrisvar þegar kveikt er á lásnum.

## 5.9 Aukabúnaður



Aukahlutir í boði eftir gerð. Skannaðu QR kóðann til að athuga hvernig nota á aukahlutina sem fylgja með heimilistækinu. Hægt er að panta aukahluti sérstaklega. Til að fá frekari upplýsingar skaltu hafa samband við söluaðilann á staðnum.

Notaðu aðeins hentug eldunaráhöld og efni. Skoðuðu kaflann „Ábendingar og ráð“, Eldunaráhöld og efni sem henta örbylgju.

Lítill sköð efst auka öryggi og veita vörn þegar þær halla. Brúnin umhverfis hilluna kemur í veg fyrir að eldunaráhöld renni niður af hillunni.

Settu aukahlutinn (stálhillu / bökunaplötu) inn á milli rásanna á hilluberanum. Gakktu úr skugga um að hillan snerti bakhlíð ofnsins og að fæturnir vísi niður.

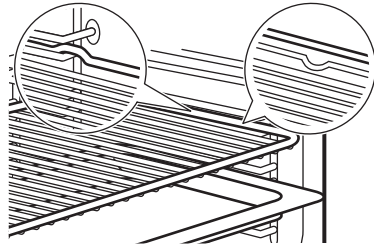

Ef bökunarplatan er með halla skaltu koma henni fyrir í átt að bakhlíð ofnsins.

Ef vírhillan er með brún skaltu koma henni fyrir í átt að framhlíð ofnsins.

Ef það er áletrun á aukahlutum skaltu ganga úr skugga um að hann snúi að þér.

Ef þú notar bakka með götum, settu annan bakka/pönnu undir til að safna vökva sem lekur niður.

## 6. ÁBENDINGAR OG GÓÐ RÁÐ

### 6.1 Ráðleggingar um eldun

Hitastig og eldunartími á töflunum er aðeins til viðmiðunar. Það fer eftir uppskriftunum, gæðum og magni hráefnisins sem notað er. Ef þú finnur ekki stillingarnar fyrir ákveðna uppskrift skaltu leita að svipaðri uppskrift.

Matreiðslu- og bökunarferli henta aðeins á einu stigi.

Teldu hillustöðurnar að neðan frá botni ofnsins.

#### Táknin á töflunni:







	Tegund matvæla
	Upphitunaraðgerð
°C	Hitastig
	Örbylgjuorka (W)
	Hillustaða
	Eldunartími (mín)
	Viðbótarupplýsingar

### 6.2 Upplýsingar fyrir prófunarstofnanir

#### Bakstur í einni hæð

Prófanir í samræmi við EN 60350-1, IEC 60350-1.







		°C		
Litlar kökur, 20 á plötu				
	2	150	18 - 28	1) 2)
	2	150	18 - 28	1) 2)
Fitulaus svampkaka				
	1	170	25 - 35	3) 2)
	1	170	28 - 38	3) 2)
Stökk lítill kaka				
	2	140	28 - 38	1) 2)
	2	140	25 - 35	1) 2)
Eplabaka				
	1	170	65 - 75	3) 4)
	1	170	57 - 67	3) 4)

				
<b>Brauðrist</b>				
	2	230	7 - 12	3) 2) 5)

- 1) Settu bökkunarplötuna með hallanum að bakhlíð ofnrýmisis. Það verður að snerta víftuhlífina.
- 2) Forhitaðu heimilistæknið þangað til hitastiginu er náð. Ekki nota aðgerðina: Hröð upphitun.
- 3) Notaðu vírhilluna.
- 4) 2 form staðsett samhliða (Ø 20 cm). Það sem er hægra megin skal vera framar en það sem er vinstra megin.
- 5) Samkvæmt: IEC 60350-1:2016 og IEC 60350-1:2023.

## Örbylgju- og samsettar örbylgjuaðgerðir

Prófanir í samræmi við EN 60705, IEC 60705.

					
<b>Svampkaka</b>					
	1	500	-	8 - 10	1) 2)

<b>Kjöthleifur</b>					
	1	300	-	30 - 35	1) 2) 3)









<b>Eggjabúðingur</b>					
	1	400	-	18 - 23	1) 4)

<b>Affrýsting á kjöthakki (500 g)</b>					
	1	200	-	7 - 8	1) 5)

<b>Kaka</b>					
	1	200	170	22 - 27	1) 4)







<b>Kartöflugratín</b>					
	1	200	180	35 - 40	1) 6)



<b>Kjúklingur (1100 g)</b>					
----------------------------	--	--	--	--	--



					
	1	200	200	30	1) 7)
	-	-	-	18 - 23	

- 1) Notaðu vírhilluna. Það verður að snerta víftuhlífina.
- 2) Snúðu ílátinu um 1/2 þegar eldunartíminn er hálfnaður.
- 3) Notaðu matarfilmu sem hægt er að setja í örbylgjuofn við eldun. Stingdu nokkur göt í matarfilmuna fyrir eldun.
- 4) Ekki snúa matvælunum meðan á eldun stendur.
- 5) Snúðu kjötinu á hvolf á langhlíðinni, einu sinni eftir 1/3 eldunartímans og aftur eftir 2/3 eldunartímans.
- 6) Snúðu ílátinu réttshlís um 1/4 þegar eldunartíminn er hálfnaður.
- 7) Settu plötu neðst í ofninum. Settu kjúkling beint á vírhilluna og snúðu bringunni niður. Eftir 30 mín skaltu snúa kjúklingnum á hvolf og breyta hitunaraðgerðinni í: Blástursgrillun.

## Viðbótaruppskriftir

					
<b>Marengs</b>					

	2	-	100	90 - 180	1) 2) 3)
	2	-	100	90 - 180	1) 2) 3)

<b>Skonsur</b>					
	3	-	200	11 - 13	1) 3)
	3	-	190	10 - 12	1) 3)

<b>Kjúklingur</b>					
	1	-	200	65 - 75	1) 4)









<b>Poppkorn</b>					
	-	700	-	3 - 4	5) 6)

<b>Matarréttir, kældir (1 skammtur)</b>					
	1	500	-	7 - 9	7) 8) 9)

<b>Vökvar í pelum fyrir börn</b>					
	-	1000	-	0,5	10)

<b>Lasagna, frosið (400 g)</b>					
	1	100	210	23 - 28	7) 11)

<b>Lasagna, frosið (600 g)</b>					
--------------------------------	--	--	--	--	--

					
	1	200	190	48 - 53	7) 11)
Frosin pítsa					
	1	200	210	12 - 16	7) 11)

- 1) Notaðu bókunarplötuna með halla að baklið ofnrýmisins.
- 2) Notaðu bókunarpappír.
- 3) Forhitaðu heimilistækið þangað til hitastiginu er náð. Ekki nota aðgerðina: Hröð upphitun.
- 4) Settu kjúklinginn inn með bringuna niður. Snúðu kjötinu á hvolf þegar eldunartíminn er hálfnaður.
- 5) Notaðu flatan keramikdisk á botni ofnhófsins.
- 6) Pokinn ætti að vera tekinn út úr heimilistækinu þegar kornin hætta að poppast.
- 7) Notaðu vírhilluna. Það verður að snerta víftuhlífina.
- 8) Hyldu matinn með plastloki sem má fara í örbylgjuofn.
- 9) Snúðu ílátinu um 1/2 þegar eldunartíminn er hálfnaður.
- 10) Settu flöskuna í miðjuna á botni rýmisins án þess að nota aukabúnað.
- 11) Ekki snúa matvælunum meðan á eldun stendur.

### 6.3 Ráðleggingar varðandi örbylgju

Settu matvöruna á miðja vírhilluna. Notaðu fyrstu hillustöðuna.

Snúðu eða hræðu í matnum þegar eldunartíminn er hálfnaður til að fá betri árangur.

Hræðu í fljótandi réttum af og til.

Hræðu í matnum áður en hann er borinn fram.

Settu skeiðina í bollann eða glasið þegar þú hitar upp vökva til að bæta hitadreifingu og forðast að það sjóði uppúr. Skeiðin má ekki snerta neinn hluta ofnsins, því það getur valdið neistamyndun.

Settu matinn inn í heimilistækið án allra umbúða. Tilbúna rétti í umbúðum má aðeins setja í heimilistækið þegar umbúðirnar eru öruggar fyrir örbylgju. Sjá Ábendingar og góð ráð, Hentug eldunarílát og efni fyrir örbylgjuofn.

Ekki hylja matinn þegar þú notar samsettar örbylgjuaðgerðir. Sjá Dagleg notkun.

Ekki nota örbylgjuaðgerðirnar eða samsettu örbylgjuaðgerðirnar þegar engin matur er inni í heimilistækinu.

### Eldun í örbylgju

Hyllið matinn sem á að elda eða hita upp með örbylgjuaðgerðum. Ef þú vilt halda skorpunni skaltu elda mat án loks.

Ekki ofelda réttina með því að stilla orku og tíma of hátt. Maturinn kann að þorna upp, brenna, eða valda eldsvoða.

Ekki skal nota heimilistækið til að sjóða egg í skurninni, eða snigla, því þau geta sprungið. Gerðu gat á eggjarauðu spæleggs áður en þú hitar það upp.

Gerðu gat á matvæli sem eru með húð eða hýði með gaffli nokkrum sinnum fyrir eldun.

Skerðu grænmeti niður í bita af svipaðri stærð.

Eftir að þú hefur slökkt á heimilistækinu skaltu taka matinn út og láta hann standa í nokkrar mínútur svo að hitinn dreifist jafnt.

### Affrysting í örbylgju

Settu frosinn, óinnpakkaðan mat á lítinn disk á hvolfi, með ílát fyrir neðan, eða á affrystingargrind eða plastsigt þannig að affrystur vökvi renni burt.

Fjarlægðu svo affryst stykki.

Þú getur notað meiri örbylgjuorku til að elda ávexti og grænmeti án þess að affrysta þá fyrst.

Snúningur bætir árangurinn. Fyrir viðkvæm matvæli eins og kjöt skaltu snúa því á hvolf tvisvar sinnum meðan á afþiðingu stendur.

### 6.4 Hentug eldunaráhöld og efni fyrir örbylgju

Notaðu aðeins hentug eldunaráhöld og efni fyrir örbylgjuna. Notaðu töfluna fyrir neðan sem viðmiðun.

Athugaðu tæknilýsingu fyrir eldunarílát / efni / matarílát fyrir notkun.

Fylgdu leiðbeiningum framleiðanda fyrir önnur sérstök örbylgjueldurnarílát sem ekki eru skráð í þessari töflu.

Eldunaráhöld / efni			
Eldfast gler og postulín án málmíhluta, t.d. hitapolið gler	✓	✓	✓
Ekki eldfast gler og postulín án neinna silfur-, gull- eða platinuskreytinga eða annarra málmस्कreytinga	✓	✗	✗
Gler og glerkeramik gert úr eldföstu/frostþolnu efni	✓	✓	✓
Keramik- og leir án kvars- eða málmíhluta og gljáa sem inniheldur máлма	✓	✓	✓
Keramik, postulín og leir með gljáalausum botni eða með litlum götum, t.d. á handföngum	✗	✗	✗
Hitapolið plast allt að 200 °C	✓	✓	✗
Pappi, eingöngu pappir	✓	✗	✗
Matarfilma	✓	✗	✗
Matarfilma fyrir örbylgju	✓	✓	✗
Steikardiskar gerðir úr málm, t.d. glerungshúðaðir, úr steypujárni	✗	✗	✗
Bökunarform, svartlökkuð eða silikonhúðuð	✗	✗	✗
Bökunarplata	✗	✗	✗
Vírhilla	✓	✓	✓

## 6.5 Orkustillingar

Upplýsingarnar að neðan eru aðeins til viðmiðunar.

### 800 - 1000 W

- Upphitun á vökva

### 600 - 700 W

- Láta hrísgrjón malla
- Elda grænmeti
- Poppkorn

### 400 - 500 W

- Hita máltíðir á einum disk

- Láta kássur malla
- Affrýsting og hitun frosinna máltíða

### 300 W

- Elda / Hita viðkvæman mat
- Hita barnamat
- Halda eldun áfram

### 100 - 200 W

- Affrýsting á brauði, ávöxtum, kökum, bakkelsi, osti, smjöri, kjöti og fisk
- Bræðing á súkkulaði og smjöri

## 7. UMHIRÐA OG HREINSUN

### 7.1 Athugasemdir varðandi þrif

- Notaðu þrifalaun til að þrifa málmfleti.
- Notaðu fljótandi kalkhreinisefni samkvæmt ráðleggingum framleiðanda til að fjarlægja kalkleifar.
- Ekki geyma mat í tækinu lengur en 20 mínútur.

- Ekki hreinsa aukahlutina í uppþvottavél.

### 7.2 Fjarlægðu hilluberana

1. Gakktu úr skugga um að heimilistækið sé kalt.
2. Togaðu hilluberana gætilega upp og út úr fremri hespunni.

3. Togaðu hilluberana úr aftari hespunni.
4. Settu hillustoðirnar aftur í sína upphaflegu stöðu. Endurtaktu skrefin í öfugri röð.

Ef útdraganlegu rennurnar fylgja með verða festipinnar þeirra að snúa fram.

### 7.3 Skipt um ljósið

#### ⚠ **ADVÖRUN!**

Hætta á að þú getir brennt þig, glerhlífir getur verið heit. Notaðu hlífðarhanska þegar þú snertir ljósaperuna.

Aðeins viðgerðarþjónustuaðilar mega skipta um ljósaperuna. Hafði samband við viðurkennda þjónustumiðstöð.

## 8. BILANALET

Ef þú getur ekki sjálf(ur) fundið lausn á vandamálinu skaltu hafa samband við söluaðila eða viðurkennda þjónustumiðstöð. Þjónustuupplýsingar eru á merkiplötunni sem er staðsett á framhluta heimilistækisins. Hún er sýnileg þegar þú opnar ofninn. Ekki fjarlægja merkiplötuna.

Ef skjárinn sýnir villukóða sem er ekki í þessari töflu skaltu slökkva og kveikja aftur á öryggistöflunni á heimilinu og endurræsa síðan heimilistækið. Ef villukóðinn kemur aftur upp skaltu hafa samband við viðurkennda þjónustumiðstöð.

**Ekki er hægt að kveikja á heimilistækinu eða nota það.** -Heimilistækið er ekki tengt við rafmagn eða það ekki rétt tengt.

**Heimilistækið hitnar ekki.**

- Lás er virkjað.
- Sjálfvirk slökkvun er virk.

**Ljósið virkar ekki.** – Ljósaperan er sprungin. Það þarf að skipta um ljósaperu, hafðu samband við viðurkennda þjónustumiðstöð.

**Skjárinn sýnir "00:00".** – Rafmagnstruflun átti sér stað. Stilltu tíma dags.

## 9. ORKUNÝTNI

### 9.1 Kröfur um upplýsingagjöf samkvæmt (ESB) nr. 2023/826

Rafmagnsnotkun í bóham	0,8 W
------------------------	-------

Hámarkstími sem þarf til að búnaðurinn nái sjálfkrafa víðeigandi lágorkuham	20 mín
---	--------

Heimilistæki prófað í samræmi við: EN 50564.

### 9.2 Ráð til að spara orku

- Haltu hurðinni lokaðri meðan á eldun stendur og forðastu að opna hana oft.
- Haltu kanti hurðarinnar hreinum og gættu þess að hann sé vel festur á sínum stað.
- Notaðu eldhúsáhöld úr málm til að bæta orkusparnað (aðeins þegar notaðar eru aðgerðir sem ekki nota örbylgjur).
- Slepptu forhitun nema þörf sé á henni.
- Lágmarkaðu hlé milli baksturs á fleiri en einum rétti.

- Þegar unnt er skal nota eldunaraðgerðir með viftu til að spara orku (einungis í völdum gerðum).
- Notaðu varmaleifar til að halda matnum heitum. Lækkaðu hitastig tækisins um að minnsta kosti 3–10 mín rétt fyrir lok eldunar.
- Slökktu á ljósinu meðan á eldun stendur. Skoðaðu „Stillingar“.
- Bökun með rökum blæstri (aðeins á völdum gerðum) – þessi aðgerð var notuð til að uppfylla kröfur um orkuflokk og vistvæna hönnun (samkvæmt EU 65/2014 og EU 66/2014). Prófanir í samræmi við: IEC/EN 60350-1. Ofnhurðin ætti að vera lokuð meðan á matreiðslu stendur þannig að aðgerðin verði ekki fyrir truflun og til þess að ofninn virki með bestu mögulegu orkunýtni. Þegar þú notar þessa aðgerð slökknar ljósið sjálfkrafa. Í sumum gerðum tekur það 30 sek.
- Ef hitunaraðgerðin er virk og engum stillingum er breytt, slekkur heimilistækið af öryggisástæðum sjálfkrafa á sér eftir

ákveðinn tíma. Ef þú átt til að hafa upphitunaraðgerð í gangi fram yfir sjálfvirka tímann þegar straumur er rofinn settu þá í gang eldunartíma.

- 12,5 klst: 30-115 °C
- 8,5 klst: 120-195 °C
- 5,5 klst: 200-245 °C
- 3 klst: 250 - hámark °C

## 10. UMHVERFISSJÓNARMÍÐ

Settu efni með tákninu  í endurvinnslu. Settu umbúðimar í viðeigandi ílát til endurvinnslu. Verndið umhverfið og heilbrigði manna með því að endurvinna raf- og rafeindabúnaðarúrgang heimilistækja. Fargaðu ekki

heimilistækjum sem merkt eru með tákninu  með heimilisúrgangi. Skilið vörinni á staðbundna endurvinnslustöð eða hafið samband við staðaryfirvöld.





