

Series 8, built-in microwave, Black BFL7221B1

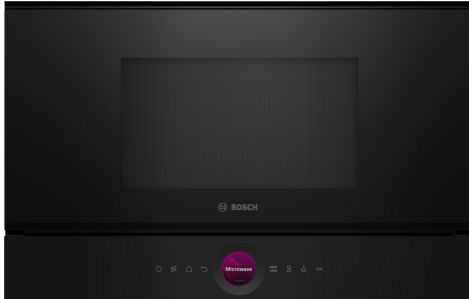

Optional accessories

HEZ6UCC0 Cookbook
HEZG9AS00S Adapter

The compact microwave 38cm. Inverter Technology: constant microwave power for heating food gradually. Microwave Boost Function: quick and easy warming.

- **Digital Control Ring:** the simple and innovative way to select oven settings.
- **TFT Touch Display:** easy control thanks to an innovative Digital Control Ring and TFT touchscreen.
- **AutoPilot 7:** every dish is a perfect success thanks to 7 pre-set automatic programmes.
- **Stainless steel interior:** easy to clean interior thanks to smooth surfaces and no sharp edges.
- **Cleaning Assistance:** less cleaning effort

Technical Data

Type of micro-wave oven: Microwave only
 Type of control: Electronic
 Dimensions: 382x594x318 mm
 Cavity dimensions: 230 x 350 x 270 mm
 Length electrical supply cord: 175 cm
 Net weight: 16.1 kg
 Gross weight: 18.7 kg
 EAN code: 4242005319985
 Maximum micro-wave power: 900 W
 Connection rating: 1220 W
 Fuse protection: 10 A
 Voltage: 220-240 V
 Frequency: 50; 60 Hz



Series 8, built-in microwave, Black BFL7221B1

The compact microwave 38cm. Inverter Technology: constant microwave power for heating food gradually. Microwave Boost Function: quick and easy warming.

Microwave and heating mode:

- Max. Power: 900 W; 5 Microwave power settings: 90 W, 180 W, 360 W, 600 W, 900 W
- Intelligent inverter technology: maximum output power will be regulated to 600 W when used in longer operation
- Cavity volume: 21 l

Design:

- stainless steel cavity with glass bottom

Cleaning:

- Cleaning Assistance

Comfort:

- electronic clock
- Touch control
- User-friendly electronics: extremely easy and comfortable Soft Touch operation.
- CookControl, 7 automatic programs
- 3 defrost and 4 cooking programmes in microwave function
- Quick start button: one tap starts maximum microwave power for 30 seconds , extra taps add 30 sek.
- LED light
- side opening door, hinge left
- open button, electric
- Touch key operation

Environment and Safety:

- Safety functions: Start-/Stop button, door contact switch
- Integral cooling fan

Technical Info:

- Length of mains cable: 175 cm
- Total connected load electric: 1.22 KW
- Nominal voltage: 220 - 240 V
- Can be built in a 60 cm wall cupboard (at least 30cm deep), Suitable for high cupboard installation

Dimensions:

- Appliance dimension (hxwxd): 382 mm x 594 mm x 318 mm
- Niche dimension (hxwxd): 362 mm - 382 mm x Cut-out/niche width (mm) min: 560 mm -Cut-out/niche width (mm) max: 568 mm x 300 mm
- "Please reference the built-in dimensions provided in the installation drawing"

Series 8, built-in microwave, Black
BFL7221B1

Measurements in mm

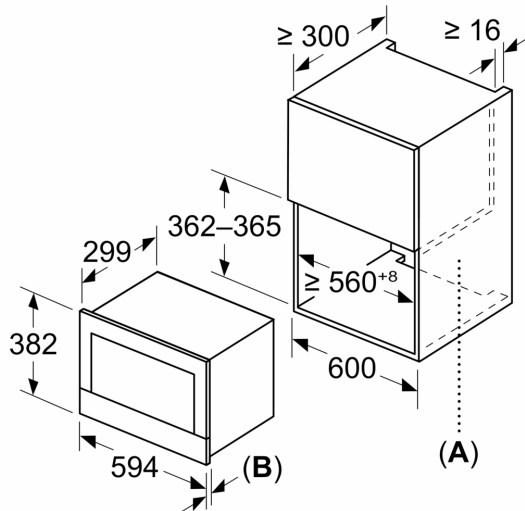

A: Back wall open
B: 19.5 mm

Measurements in mm

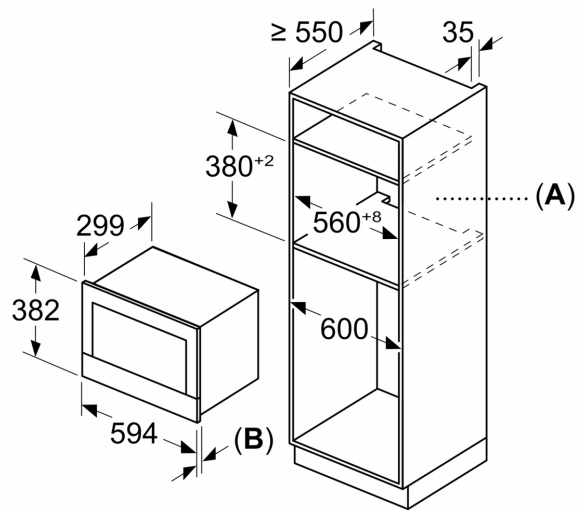

A: Back wall open
B: 19.5 mm

measurements in mm

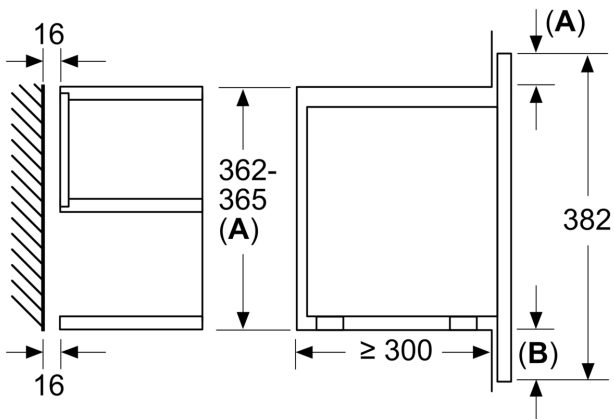

A: Overhang at top:
 Recess 362: 6 mm
 Recess 365: 3 mm
B: Overhang at bottom: 14 mm